

Sensor Base Kit – Model Year 2023 or older

Items Included in the Kit

Unpack the kit and review its contents.

<p>HUB/Controller Kit Quantity: 1 DF Part Number: BASE-100</p> 	<p>WiFi/Bluetooth to CAN Bridge Kit Quantity: 1 DF Part Number: GEN-103</p> 
<p>M12 Cordset, 2M Cable Kit Quantity: 1 DF Part Number: GEN-104</p> 	<p>Harness, Controller/HUB Power Kit Quantity: 1 (if applicable) DF Part Number: HARN-PWR-002</p> <p>(Power wiring is pre-installed in a HARN-PWR-003 harness.)</p> 
<p>Male Terminals DF Part Number: GEN-110</p> 	<p>Female Terminals DF Part Number: GEN-101</p> 

CAN Bus Harness: One of the following harnesses are included (truck specific).

<p>Harness, Chassis CAN Kit Quantity: 1 (if applicable) DF Part Number: HARN-CAN-001</p> 	<p>Harness, Chassis CAN Kit Quantity: 1 (if applicable) DF Part Number: HARN-CAN-FDM</p> 	<p>Harness, Chassis CAN Kit Quantity: 1 (if applicable) DF Part Number: HARN-BLK-OB-D-J1939</p> 
<p>Harness, Chassis CAN Kit Quantity: 1 (if applicable) DF Part Number: HARN-CAN-003</p> <p>(Harness includes a terminating resistor preinstalled.)</p>   <p>Terminating Resistor</p>	<p>Harness, Chassis CAN Kit Quantity: 1 (if applicable) DF Part Number: HARN-BECK-001</p>  <p>w3s-j1939 Wedglock Dt06-3s Connector</p> 	<p>Harness, Chassis CAN Kit Quantity: 1 (if applicable) DF Part Number: HARN-PWR-003</p>  <p>Harness includes connectors for chassis PWR, IGN, and GND.</p>

Mixer CAN Harness: One of the following harnesses are included (truck specific).

Harness, Mixer CAN

Kit Quantity: 1 (if applicable)

DF Part Number: [HARN-CAN-002](#)

(For trucks **without** a Mixer CAN Control System; harness includes a terminating resistor (plug) on each connector.)



Terminating Resistor

Harness, Mixer CAN

Kit Quantity: 1 (if applicable)

DF Part Number: [HARN-FLEX-001](#)

(Only for trucks **with** a Mixer CAN Control System; harness includes a terminating resistor preinstalled.)

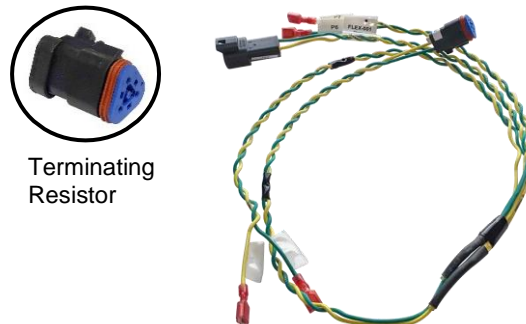

Terminating Resistor

Harness, Mixer CAN

Kit Quantity: 1 (if applicable)

DF Part Number: [HARN-ELITE-001](#)

(Only for trucks **with** a Mixer CAN Control System.)

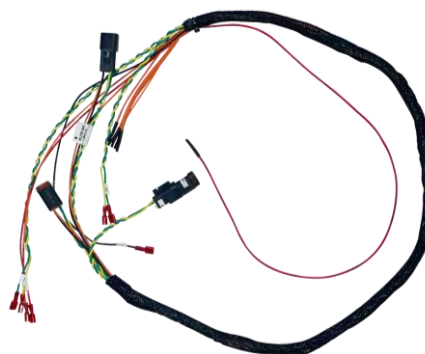
**Tools for the Job** (not included)

- #2 Phillips screwdriver (or screw gun with #2 Phillips end)
- Flat/Torq/Square screwdrivers or screw gun bits (alternate dashes)
- Wire crimpers
- Wire strippers
- Side cutters
- Light
- Drill/bits (holes to run wiring through dash)

Additional Items Needed (not included)

- Grommets, bushings, hole plugs (to pass wiring through dash/firewall)
- Wire ties
- Colored tape (to mark cables)
- Screws/fasteners

Installation – Sensor Base Kit

This section covers the general installation steps for the Sensor Base Kit.

During Installation You Will:

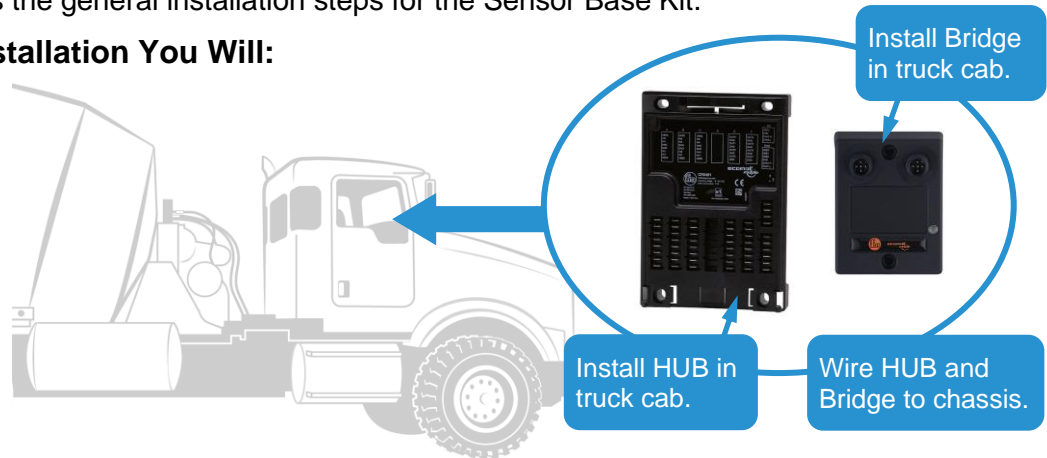

INSTALLATION

The Sensor Base Kit is tailored to your truck (model/make/year).

- Step 1.** Turn engine off, but leave battery connected (battery power is connected in a later step).
- Step 2.** Locate truck’s wiring connections (CAN, battery power, ground, and ignition)—see **Chassis CAN and Power Connections** section for typical locations.
- Step 3.** Remove appropriate panel(s) to access connections.
- Step 4.** Select the Wire Diagram (from table below) that matches your kit harness configuration:

Wire Diagrams are located at end of this Sensor Base Kit section.

Mixer Type	If your kit includes Harness(es):			Use Sensor Base Wire Diagram:	Dia. No.
	Chassis CAN	Power	Mixer CAN		
Rear	HARN-CAN-001	HARN-PWR-002	HARN-CAN-002	Sensor Base - Standard	1
	HARN-CAN-001	HARN-PWR-002	HARN-FLEX-001	Sensor Base (Flex or Raven) Use for mixer harness to connect to dash harness MC20 on FLEX, or MC17 on Raven	2
				Sensor Base (Kimble K2200) Use for mixer harness to connect to cab box, 3-way DT splitter on Kimble K2200	3
	HARN-CAN-003	HARN-PWR-002	HARN-CAN-002	Sensor Base (Kimble Cyclone)	4
	HARN-CAN-001	HARN-ELITE-001		Sensor Base (ELITE)	5
	HARN-BECK-001	HARN-PWR-002	HARN-CAN-002	Sensor Base Beck Electric	6
	HARN-PWR-003		HARN-CAN-002	Sensor Base - Freightliner/Western Star 2023 or newer	7
Front	HARN-CAN-003	HARN-PWR-002	HARN-FLEX-001	Sensor Base (Terex Advance) 2019 or newer	8
	HARN-CAN-003	HARN-PWR-002	HARN-CAN-002	Sensor Base (Terex Advance) 2016–2019 (no Mixer CAN)	9
	HARN-BLK-OBDD-1939	HARN-PWR-002	HARN-CAN-002	Sensor Base (Terex Advance) 2016 or older (no Mixer CAN)	10
	HARN-CAN-003	HARN-PWR-002	HARN-CAN-002	Sensor Base (Oshkosh S Series Flex 2.0)	11
				Sensor Base (Oshkosh S-Series Non Flex) (no Mixer CAN) 3-way Chassis CAN connector	12
	HARN-CAN-FDM	HARN-PWR-002	HARN-CAN-002	Sensor Base (Oshkosh S-Series Non Flex) (no Mixer CAN) 6-way Chassis CAN connector	13
	N/A	HARN-PWR-002	HARN-CAN-002	Sensor Base (Oshkosh S-Series Non Flex) Glider (no Chassis/Mixer CAN)	14

Important Note: When wiring, always make the chassis power/ground connection to the Hub last. If mounting the Hub or Bridge to a panel, fasten it before starting any wiring.

Step 5. Install Sensors (if applicable—Drum, Slump, Water Add, Washout, Quad)

To install and wire a new sensor—reference the appropriate sensor installation section.

To wire a preinstalled sensor to the Hub—use the wiring instructions from the appropriate DF+ sensor installation section.

For Example: To wire a preinstalled slump sensor, reference wiring instructions in the DF+ Slump Kit section.

Step 6. Install the DF+ Tablet Charger to the Hub, reference the Tablet Installation section.

To wire a preinstalled charger to the Hub—use the wiring instructions from the Tablet Installation section.

Step 7.  Use Wire Diagram selected from table on previous page as reference for next steps.
Important: Route cables safely—avoid moving parts, pinch points, and sharp edges. Use a grommet or bushing on pass-thru holes as needed.

7.1. Wire Hub to Chassis CAN Bus—see Wire Diagram .

7.2. Connect Bridge to Hub—see Wire Diagram .

7.3. Connect Hub to chassis ignition, ground, and power—see Wire Diagram .

Step 8. When installation is complete, make sure all wiring connections are securely fastened.**Step 9.** Verify the DF System is connected and functioning properly, reference the DF+ Verification Instructions (navigates the digital verification process).

For installation questions, please call DF+ Support at 630.518.4606.

Wire Diagram 1 Sensor Base, Standard

Use diagram below along with the Sensor Base Kit installation steps.

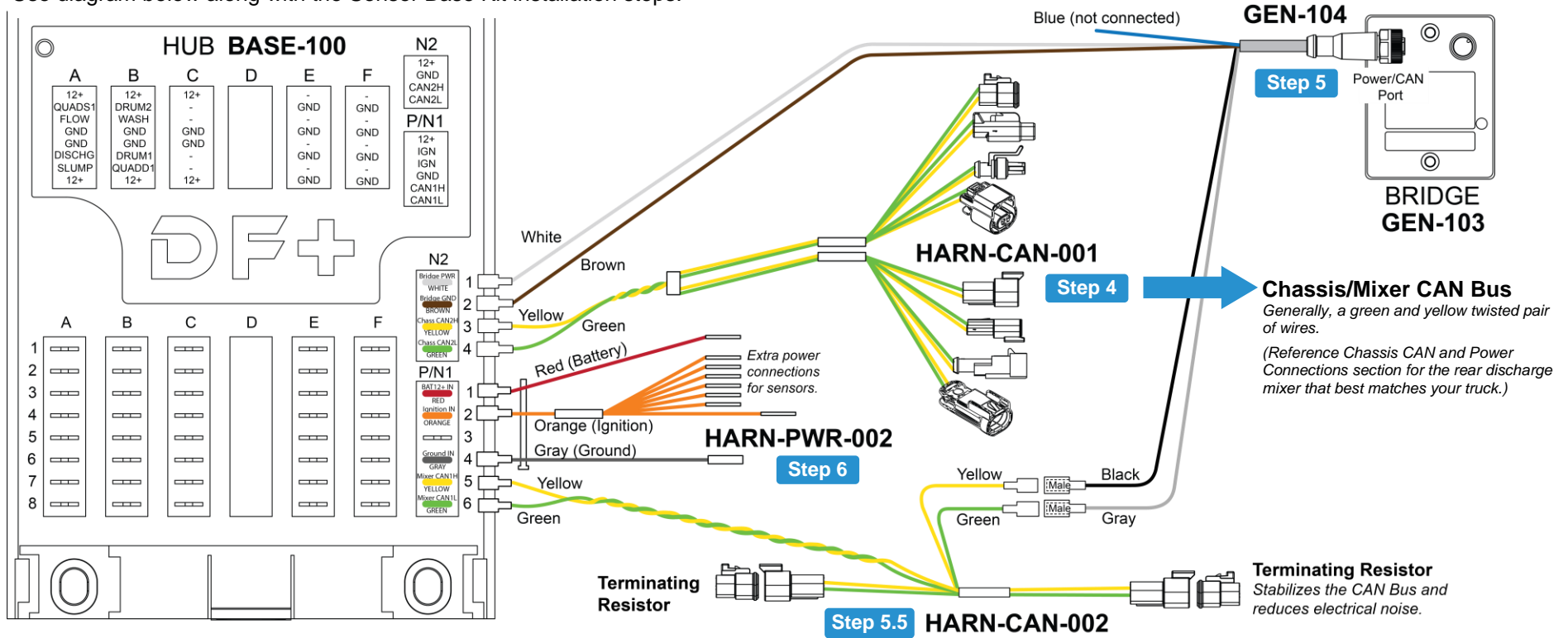

Step 4. Connect Hub to Chassis CAN Bus (use HARN-CAN-001)

- 4.1. Locate chassis CAN connector (connector is labeled)—reference Chassis CAN and Power Connections section for the rear discharge mixer that best matches your truck.
- 4.2. Plug HARN-CAN-001 into CAN Bus—use the pair of connectors that fits your chassis, see diagram.
- 4.3. **Plug remaining non-used pairs together** to prevent water intrusion.
- 4.4. Plug HARN-CAN-001 into Hub, see diagram.

Important: When routing wires to Hub, follow an existing wire path, or remove a rubber hole plug—watch for sharp edges, use a grommet or bushing on holes to prevent wire damage.

Step 5. Connect Bridge to Hub (use GEN-104)

- 5.1. Plug GEN-104 into Power/CAN port on Bridge.
- 5.2. Blue wire not used.
- 5.3. Strip remaining wires—crimp on terminals.
 - white/brown—female terminals (GEN-101)
 - black/gray—male terminals (GEN-110)
- 5.4. Plug white and brown wires into Hub, see diagram.

HARN-CAN-002

- 5.5. Connect black and gray wires to HARN-CAN-002.
- 5.6. Plug HARN-CAN-002 into Hub, see diagram.
- 5.7. Truck **does not** have a mixer CAN Bus—a terminating resistor is preinstalled in each connector (do not remove), see diagram.

Step 6. Connect Hub to Chassis Power, Ignition, and Ground (use HARN-PWR-002)

- 6.1. Locate chassis connections for battery power, ignition, and ground—connections are labeled. **Always connect power or ground to Hub last.**
- 6.2. Long harness wires (red, orange, and gray) have a TE terminal end (for a splice block). If needed, cut terminal off, strip end, and crimp on appropriate terminal provided in kit (i.e., ring terminal).

Note: Extra orange wires are provided for sensors, if needed. Connect sensors before connecting battery power to Hub (see sensor section).
- 6.3. Connect **long wire ends** to truck connectors (i.e., splice blocks, terminal posts, bullet connections): Orange (to IGN); Gray (to GND); Red (to PWR)
- 6.4. Connect female terminal ends to Hub, see diagram: Orange (IGN) to N1-2; Gray (GND) to N1-4; Red (Battery PWR) to N1-1

Wire Diagram 2 Sensor Base (Flex or Raven)

Use diagram below along with the Sensor Base Kit installation steps.

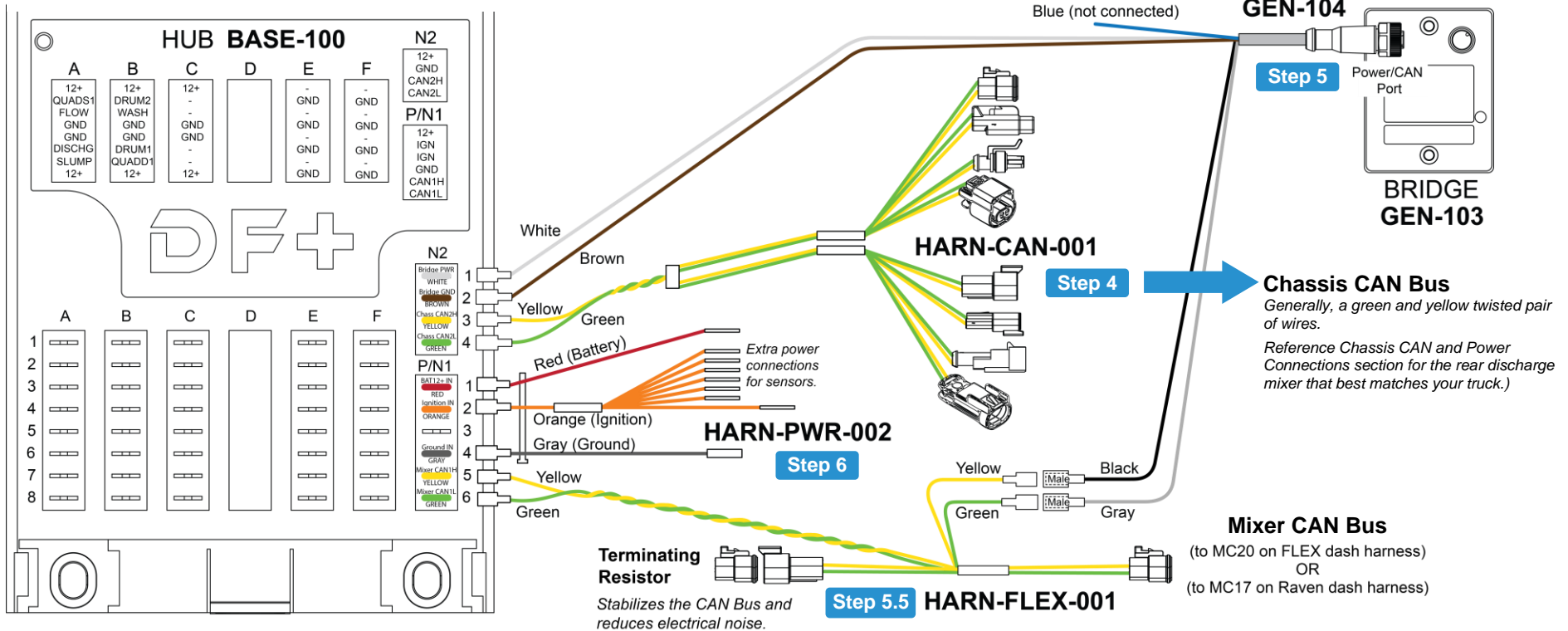

Step 4. Connect Hub to Chassis CAN Bus (use HARN-CAN-001)

- 4.1. Locate chassis CAN connector (connector is labeled)—reference Chassis CAN and Power Connections section for the rear discharge mixer that best matches your truck.
- 4.2. Plug HARN-CAN-001 into CAN Bus—use the pair of connectors that fits your chassis, see diagram.
- 4.3. **Plug remaining non-used pairs together** to prevent water intrusion.
- 4.4. Plug HARN-CAN-001 into Hub, see diagram.

Important: When routing wires to Hub, follow an existing wire path, or remove a rubber hole plug—watch for sharp edges, use a grommet or bushing on holes to prevent wire damage.

Step 5. Connect Bridge to Hub (use GEN-104)

- 5.1. Plug GEN-104 into Power/CAN port on Bridge.
- 5.2. Blue wire not used.
- 5.3. Strip remaining wires—crimp on terminals.
 - white/brown—female terminals (GEN-101)
 - black/gray—male terminals (GEN-110)
- 5.4. Plug white and brown wires into Hub, see diagram.

HARN-FLEX-001

- 5.5. Connect black and gray wires to HARN-FLEX-001.
- 5.6. Plug HARN-FLEX-001 into Hub, see diagram.
- 5.7. Locate mixer CAN Bus connector in dash (MC20 or MC17)—plug HARN-FLEX-001 into the connector, see diagram.
- 5.8. **Plug a terminating resistor** into remaining connector on the harness.

Step 6. Connect Hub to Chassis Power, Ignition, and Ground (use HARN-PWR-002)

- 6.1. Locate chassis connections for battery power, ignition, and ground—connections are labeled. **Always connect power or ground to Hub last.**
- 6.2. Long harness wires (red, orange, and gray) have a TE terminal end (for a splice block). If needed, cut terminal off, strip end, and crimp on appropriate terminal provided in kit (i.e., ring terminal).

Note: Extra orange wires are provided for sensors, if needed. Connect sensors before connecting battery power to Hub (see sensor section).
- 6.3. Connect **long wire ends** to truck connectors (i.e., splice blocks, terminal posts, bullet connections): Orange (to IGN); Gray (to GND); Red (to PWR)
- 6.4. Connect female terminal ends to Hub, see diagram: Orange (IGN) to N1-2; Gray (GND) to N1-4; Red (Battery PWR) to N1-1.

Wire Diagram 4 Sensor Base (Kimble Cyclone)

Use diagram below along with the Sensor Base Kit installation steps.

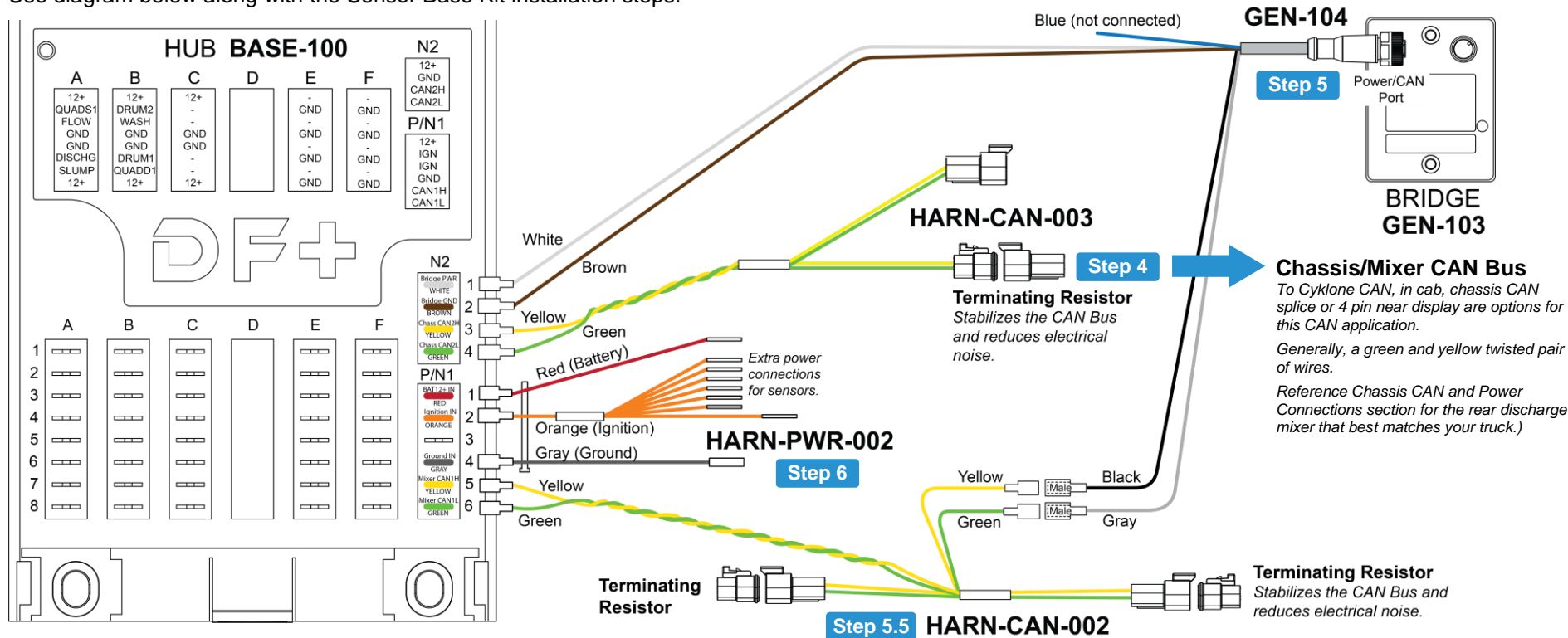

Step 4. Connect Hub to Chassis CAN Bus (use HARN-CAN-003)

- 4.1. Locate chassis CAN connector (connector is labeled)—reference Chassis CAN and Power Connections section for the rear discharge mixer that best matches your truck.
- 4.2. Plug HARN-CAN-003 into CAN Bus connection, see diagram.
- 4.3. **Plug a terminating resistor** into remaining connector on the harness.
- 4.4. Plug HARN-CAN-003 into Hub, see diagram.

Important: When routing wires to Hub, follow an existing wire path, or remove a rubber hole plug—watch for sharp edges, use a grommet or bushing on holes to prevent wire damage.

Step 5. Connect Bridge to Hub (use GEN-104)

- 5.1. Plug GEN-104 into Power/CAN port on Bridge.
- 5.2. Blue wire not used.
- 5.3. Strip remaining wires—crimp on terminals.
 - white/brown—female terminals (GEN-101)
 - black/gray—male terminals (GEN-110)
- 5.4. Plug white and brown wires into Hub, see diagram.

HARN-CAN-002

- 5.5. Connect black and gray wires to HARN-CAN-002.
- 5.6. Plug HARN-CAN-002 into Hub, see diagram.
- 5.7. Truck **does not** have a mixer CAN Bus—a terminating resistor is preinstalled in each connector (do not remove), see diagram.

Step 6. Connect Hub to Chassis Power, Ignition, and Ground (use HARN-PWR-002)

- 6.1. Locate chassis connections for battery power, ignition, and ground—connections are labeled. **Always connect power or ground to Hub last.**
- 6.2. Long harness wires (red, orange, and gray) have a TE terminal end (for a splice block). If needed, cut terminal off, strip end, and crimp on appropriate terminal provided in kit (i.e., ring terminal).

Note: Extra orange wires are provided for sensors, if needed. Connect sensors before connecting battery power to Hub (see sensor section).
- 6.3. Connect **long wire ends** to truck connectors (i.e., splice blocks, terminal posts, bullet connections): Orange (to IGN); Gray (to GND); Red (to PWR)
- 6.4. Connect female terminal ends to Hub, see diagram: Orange (IGN) to N1-2; Gray (GND) to N1-4; Red (Battery PWR) to N1-1.

Wire Diagram 5 Sensor Base (Elite)

Use diagram below along with the Sensor Base Kit installation steps.

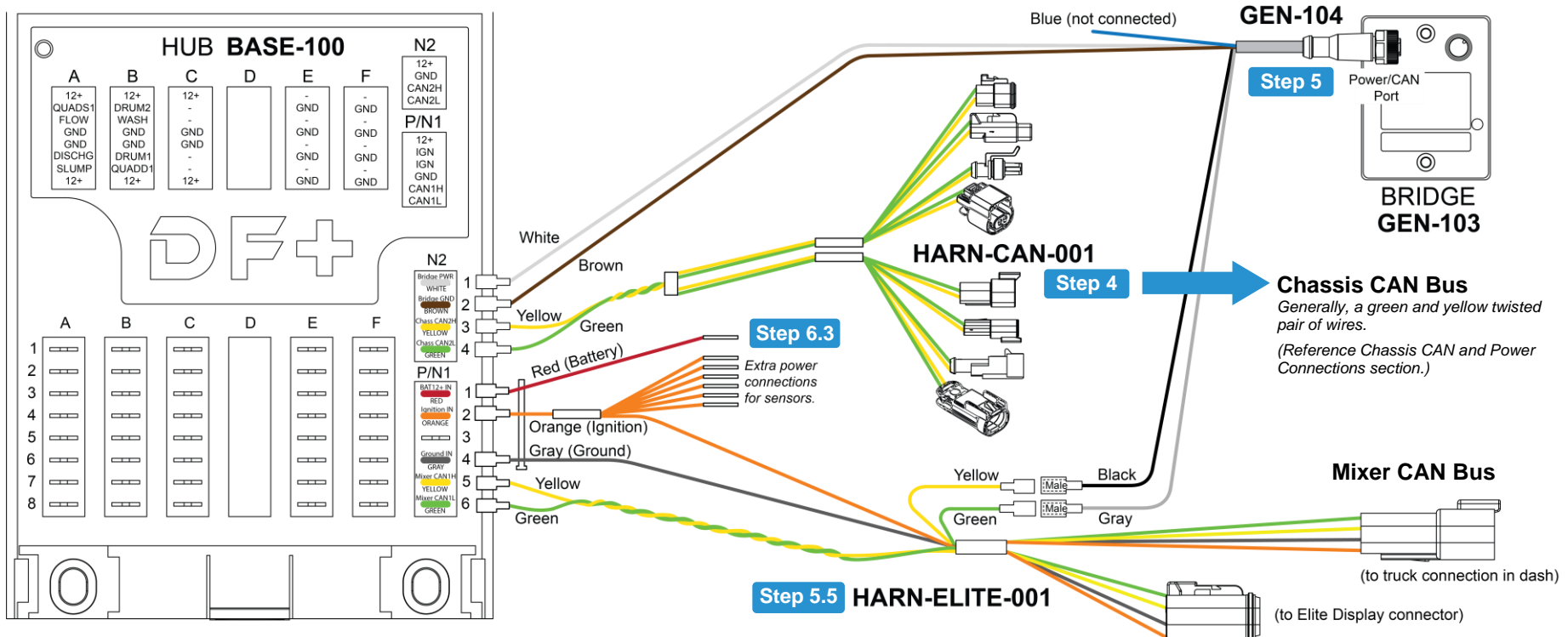

Step 4. Connect Hub to Chassis CAN Bus (use HARN-CAN-001)

- 4.1. Locate chassis CAN connector (connector is labeled)—reference Chassis CAN and Power Connections section for the rear discharge mixer that best matches your truck.
- 4.2. Plug HARN-CAN-001 into CAN Bus—use the pair of connectors that fits your chassis, see diagram.
- 4.3. **Plug remaining non-used pairs together to prevent water intrusion.**
- 4.4. Plug HARN-CAN-001 into Hub, see diagram.

Important: When routing wires to Hub, follow an existing wire path, or remove a rubber hole plug—watch for sharp edges, use a grommet or bushing on holes to prevent wire damage.

Step 5. Connect Bridge to Hub (use GEN-104)

- 5.1. Plug GEN-104 into Power/CAN port on Bridge.
 - 5.2. Blue wire not used.
 - 5.3. Strip remaining wires—crimp on terminals.
 - white/brown—female terminals (GEN-101)
 - black/gray—male terminals (GEN-110)
 - 5.4. Plug white and brown wires into hub, see diagram.
- HARN-ELITE-001**
- 5.5. Connect black and gray wires to HARN-ELITE-001.
 - 5.6. **Plug harness into mixer CAN Bus:**
 - Unplug the 4-pin connector from back of Elite Display.
 - Plug the matching HARN-ELITE-001 connector end into the Elite Display.
 - Plug remaining connector end into the mixer CAN Bus connection.

Step 6. Connect Chassis Power, Ignition, and Ground to Hub

- 6.1. Locate chassis connection for battery power. **Always connect power or ground to Hub last.**
- 6.2. The long red harness wire has a TE terminal end (for a splice block). If needed, cut terminal off, strip end, and crimp on appropriate terminal provided in kit (i.e., ring terminal).

Note: Extra orange wires are provided for added sensors, if needed. Make sensor connections before connecting power (see sensor section).
- 6.3. Connect **long red harness wire** to truck battery power connection.
- 6.4. Connect remaining female terminal ends of harness to Hub, see diagram: Orange (IGN) to N1-2; Gray (GND) to N1-4; Red (Battery PWR) to N1-1.

Wire Diagram 6 Sensor Base Beck Electric

Use diagram below along with the Sensor Base Kit installation steps.

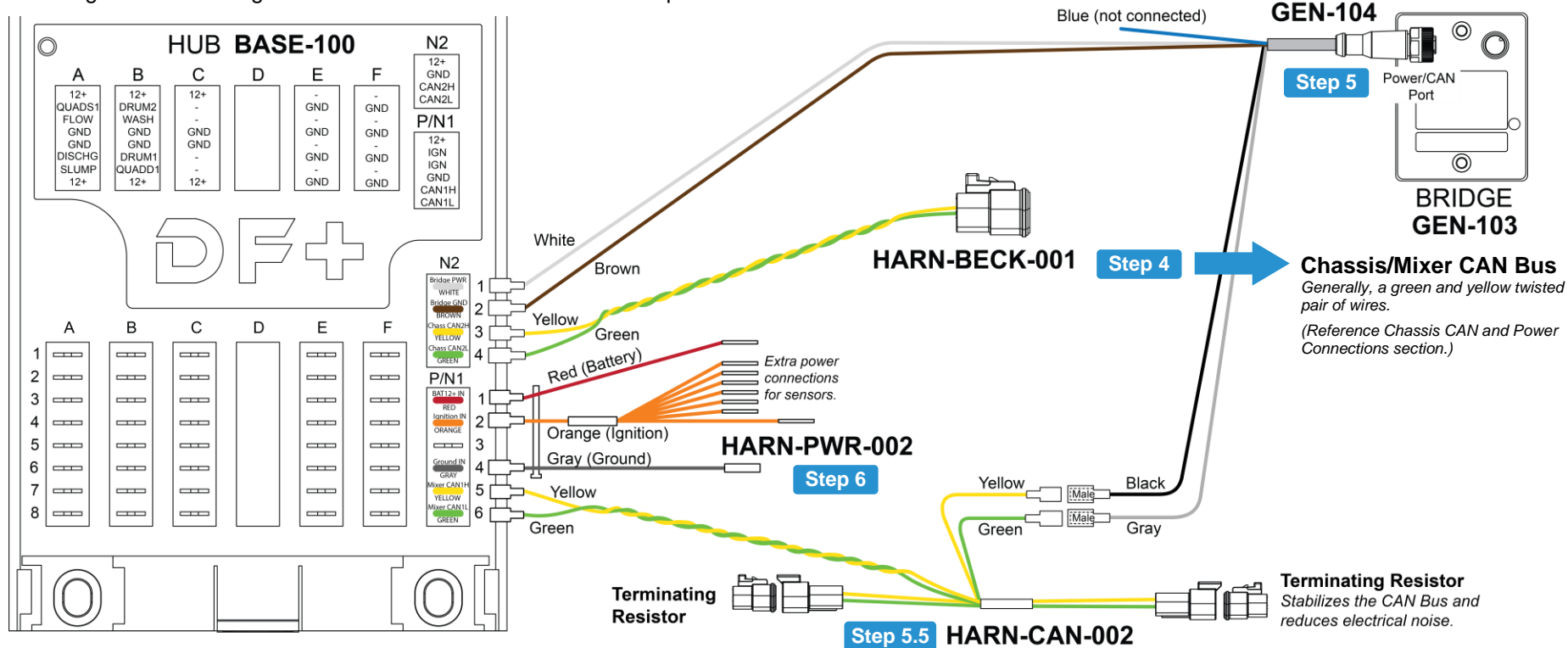

Step 4. Connect Hub to Chassis/Mixer CAN Bus (use HARN-BECK-001)

- 4.1. Locate chassis CAN connector (connector is labeled)—reference Chassis CAN and Power Connections section for the rear discharge mixer that best matches your truck.
- 4.2. Plug HARN-CAN-001 into CAN Bus—use the pair of connectors that fits your chassis, see diagram.
- 4.3. **Plug remaining non-used pairs together to prevent water intrusion.**
- 4.4. Plug HARN-CAN-001 into Hub, see diagram.

Important: When routing wires to Hub, follow an existing wire path, or remove a rubber hole plug—watch for sharp edges, use a grommet or bushing on holes to prevent wire damage.

Step 5. Connect Bridge to Hub (use GEN-104)

- 5.1. Plug GEN-104 into Power/CAN port on Bridge.
- 5.2. Blue wire not used.
- 5.3. Strip remaining wires—crimp on terminals.
 - white/brown—female terminals (GEN-101)
 - black/gray—male terminals (GEN-110)
- 5.4. Plug white and brown wires into hub, see diagram.

HARN-CAN-002

- 5.5. Connect black and gray wires to HARN-CAN-002.
- 5.6. Plug HARN-CAN-002 into Hub, see diagram.
- 5.7. Truck **does not** have a mixer CAN Bus—a terminating resistor is preinstalled in each connector (do not remove), see diagram.

Step 6. Connect Chassis Power, Ignition, and Ground to Hub

- 6.1. Locate chassis connection for battery power. **Always connect power or ground to Hub last.**
- 6.2. The long red harness wire has a TE terminal end (for a splice block). If needed, cut terminal off, strip end, and crimp on appropriate terminal provided in kit (i.e., ring terminal).

Note: Extra orange wires are provided for added sensors, if needed. Make sensor connections before connecting power (see sensor section).
- 6.3. Connect **long red harness wire** to truck battery power connection.
- 6.4. Connect remaining female terminal ends of harness to Hub, see diagram: Orange (IGN) to N1-2; Gray (GND) to N1-4; Red (Battery PWR) to N1-1.
- 6.5. (Battery PWR) to N1-1.

Wire Diagram 7 Sensor Base – Freightliner/Western Star 2023 or newer

Use diagram below along with the Sensor Base Kit installation steps.

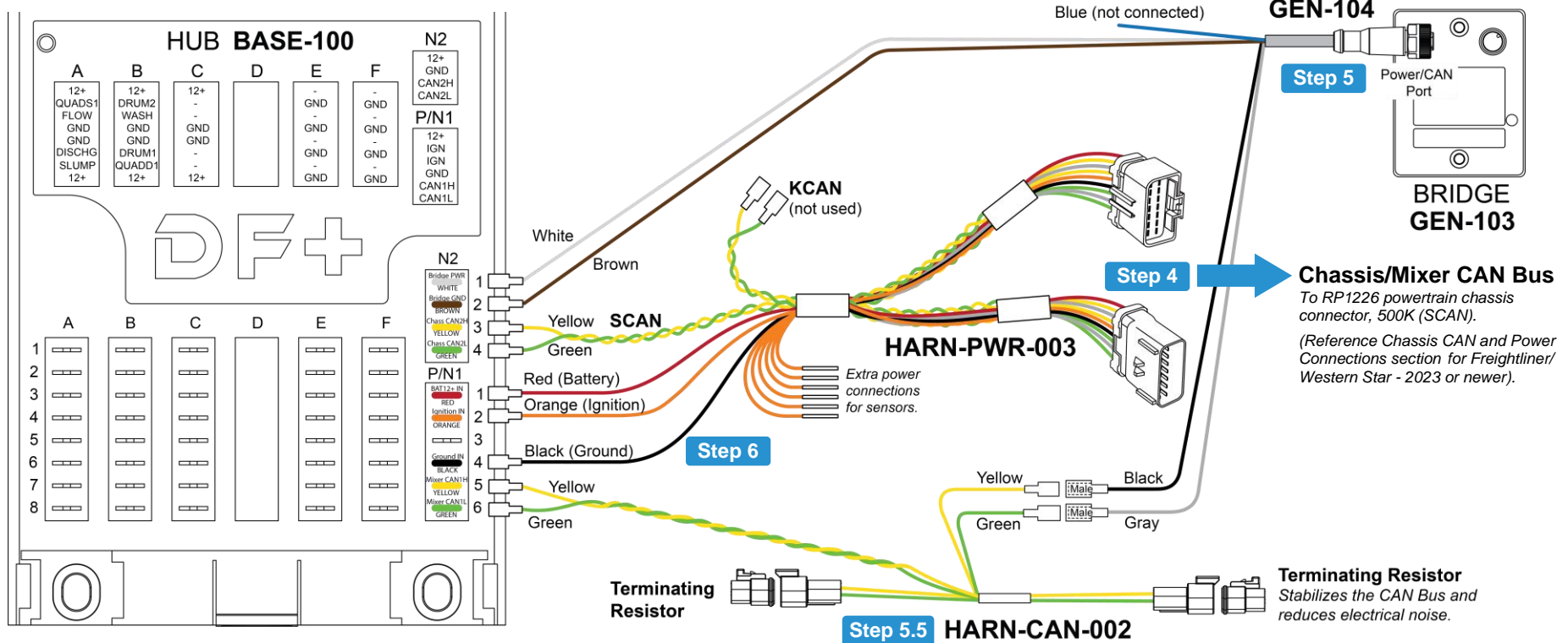

Step 4. Connect Hub to Chassis/Mixer CAN Bus (use HARN-PWR-003)

- 4.1. Locate chassis CAN connector RP1226 (connector is labeled)—reference Chassis CAN and Power Connections section for Freightliner/Western Star - 2023 or newer.
- 4.2. Unplug the RP1226 chassis connector; then plug **both** ends into HARN-PWR-003, see diagram.
- 4.3. Plug HARN-PWR-003 into Chassis CAN on Hub (N2-3 and N2-4), see diagram. Use the yellow and green twisted pair of wires marked for **SCAN** to connect to the HUB (KCAN not used).

Power wires are connected to Hub in a later step.

Important: When routing wires to Hub, follow an existing wire path, or remove a rubber hole plug—watch for sharp edges, use a grommet or bushing on holes to prevent wire damage.

Step 5. Connect Bridge to Hub (use GEN-104)

- 5.1. Plug GEN-104 into Power/CAN port on Bridge.
- 5.2. Blue wire not used.
- 5.3. Strip remaining wires—crimp on terminals.
 - white/brown—female terminals (GEN-101)
 - black/gray—male terminals (GEN-110)
- 5.4. Plug white and brown wires into Hub, see diagram.

HARN-CAN-002

- 5.5. Connect black and gray wires to HARN-CAN-002.
- 5.6. Plug HARN-CAN-002 into Hub, see diagram.
- 5.7. Truck **does not** have a mixer CAN Bus—a terminating resistor is preinstalled in each connector (do not remove), see diagram.

Step 6. Connect Hub to Chassis Power, Ignition, and Ground (use HARN-PWR-003)

- 6.1. Connect Orange (IGN) wire with female terminal end to N1-2.

Note: Extra orange wires are provided for sensors, if needed. Connect sensors before connecting battery power to Hub (see sensor section).
- 6.2. Connect Black (GND) wire with female terminal end to N1-4; connect Red (Battery PWR) wire with female terminal end to N1-1.

Wire Diagram 8 Sensor Base (Terex Advance): 2019 or newer

Use diagram below along with the Sensor Base Kit installation steps.

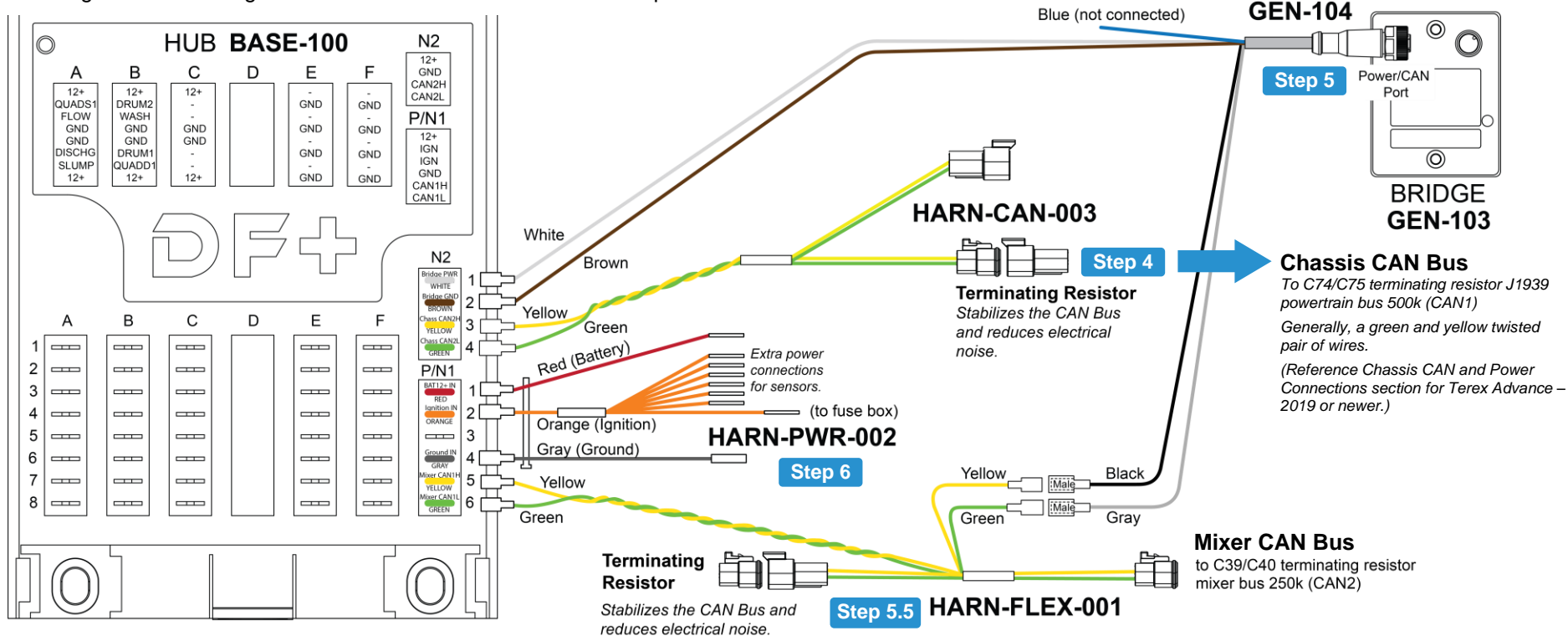

Step 4. Connect Hub to Chassis CAN Bus (use HARN-CAN-003)

- 4.1. Chassis and Mixer are on the same CAN Bus—locate the C74/C75 powertrain (CAN1) connection (connector is labeled); reference Chassis CAN and Power Connections section for Terex Advance – 2019 or newer.
- 4.2. Plug HARN-CAN-003 into C74/75 CAN Bus connection, see diagram.
- 4.3. **Plug a terminating resistor** into remaining connector on the harness.
- 4.4. Plug HARN-CAN-003 into Hub, see diagram.

Important: When routing wires to Hub, follow an existing wire path, or remove a rubber hole plug—watch for sharp edges, use a grommet or bushing on holes to prevent wire damage.

Step 5. Connect Bridge to Hub (use GEN-104)

- 5.1. Plug GEN-104 into Power/CAN port on Bridge.
- 5.2. Blue wire not used.
- 5.3. Strip remaining wires—crimp on terminals.
 - white/brown—female terminals (GEN-101)
 - black/gray—male terminals (GEN-110)
- 5.4. Plug white and brown wires into Hub, see diagram.

HARN-FLEX-001

- 5.5. Connect black and gray wires to HARN-FLEX-001.
- 5.6. Plug HARN-FLEX-001 into Hub, see diagram.
- 5.7. Locate C39/C40 mixer bus (CAN2) connector and plug HARN-FLEX-001 into connector, see diagram.
- 5.8. **Plug a terminating resistor** into remaining connector on the harness.

Step 6. Connect Hub to Chassis Power, Ignition, and Ground (use HARN-PWR-002)

- 6.1. Locate chassis connections for battery power, ignition, and ground—connections are labeled. **Always connect power or ground to Hub last.**
- 6.2. Long harness wires (red, orange, and gray) have a TE terminal end (for a splice block). If needed, cut terminal off, strip end, and crimp on appropriate terminal provided in kit (i.e., ring terminal).

Note: Extra orange wires are provided for sensors, if needed. Connect sensors before connecting battery power to Hub (see sensor section).
- 6.3. Connect **long wire ends** to truck connectors (i.e., splice blocks, terminal posts, bullet connections): Orange (to IGN); Gray (to GND); Red (to PWR)
- 6.4. Connect female terminal ends to Hub, see diagram: Orange (IGN) to N1-2; Gray (GND) to N1-4; Red (Battery PWR) to N1-1.

Wire Diagram 9 Sensor Base (Terex Advance): 2016–2019 (no Mixer CAN)

Use diagram below along with the Sensor Base Kit installation steps.

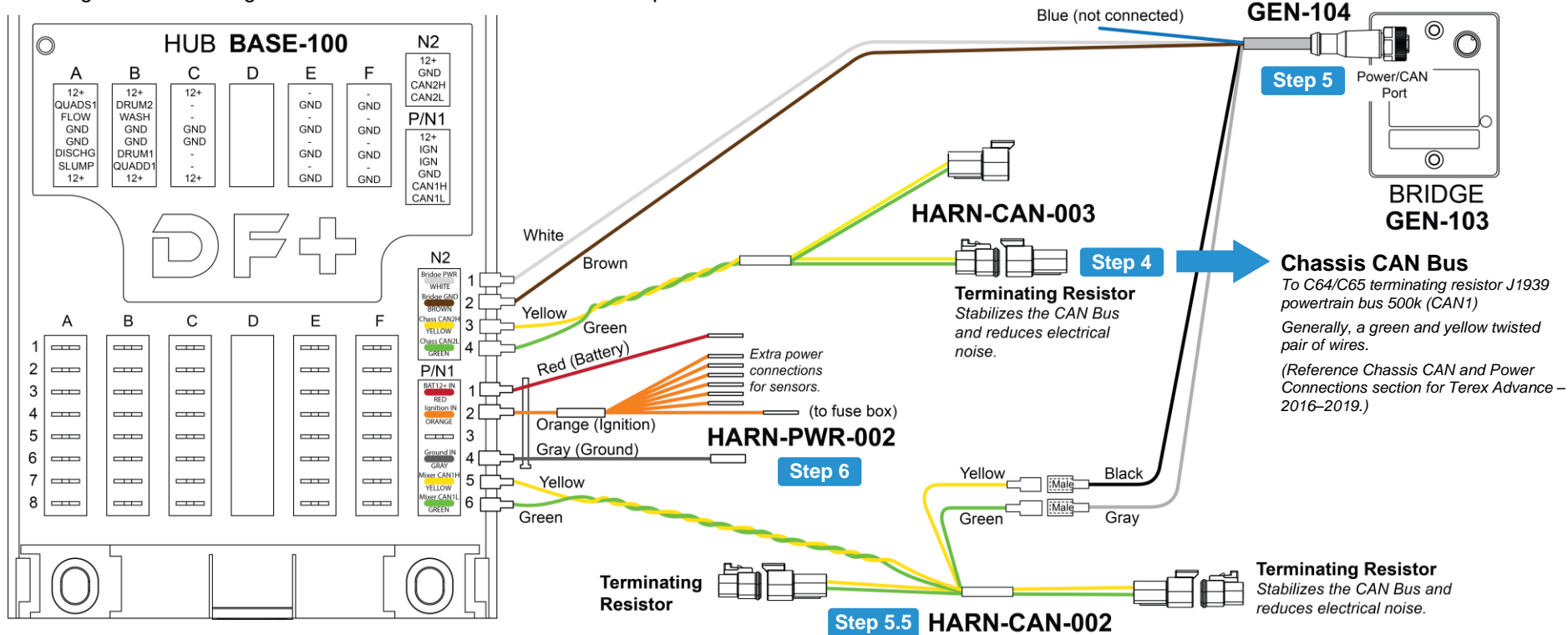

Step 4. Connect Hub to Chassis CAN Bus (use HARN-CAN-003)

- 4.1. Chassis and Mixer are on the same CAN Bus—locate the C64/C65 powertrain (CAN1) connection (connector is labeled); reference Chassis CAN and Power Connections for Terex Advance – 2016–2019.
- 4.2. Plug HARN-CAN-003 into C64/65 CAN Bus connection, see diagram.
- 4.3. **Plug a terminating resistor** into remaining connector on the harness.
- 4.4. Plug HARN-CAN-003 into Hub, see diagram.

Important: When routing wires to Hub, follow an existing wire path, or remove a rubber hole plug—watch for sharp edges, use a grommet or bushing on holes to prevent wire damage.

Step 5. Connect Bridge to Hub (use GEN-104)

- 5.1. Plug GEN-104 into Power/CAN port on Bridge.
- 5.2. Blue wire not used.
- 5.3. Strip remaining wires—crimp on terminals.
 - white/brown—female terminals (GEN-101)
 - black/gray—male terminals (GEN-110)
- 5.4. Plug white and brown wires into Hub, see diagram.

HARN-CAN-002

- 5.5. Connect black and gray wires to HARN-CAN-002.
- 5.6. Plug HARN-CAN-002 into Hub, see diagram.
- 5.7. Truck **does not** have a mixer CAN Bus—a terminating resistor is preinstalled in each connector (do not remove), see diagram.

Step 6. Connect Hub to Chassis Power, Ignition, and Ground (use HARN-PWR-002)

- 6.1. Locate chassis connections for battery power, ignition, and ground—connections are labeled. **Always connect power or ground to Hub last.**
- 6.2. Long harness wires (red, orange, and gray) have a TE terminal end (for a splice block). If needed, cut terminal off, strip end, and crimp on appropriate terminal provided in kit (i.e., ring terminal).

Note: Extra orange wires are provided for sensors, if needed. Connect sensors before connecting battery power to Hub (see sensor section).
- 6.3. Connect **long wire ends** to truck connectors (i.e., splice blocks, terminal posts, bullet connections): Orange (to IGN); Gray (to GND); Red (to PWR)
- 6.4. Connect female terminal ends to Hub, see diagram: Orange (IGN) to N1-2; Gray (GND) to N1-4; Red (Battery PWR) to N1-1.

Wire Diagram 10 Sensor Base (Terex Advance): 2016 or older (no Mixer CAN)

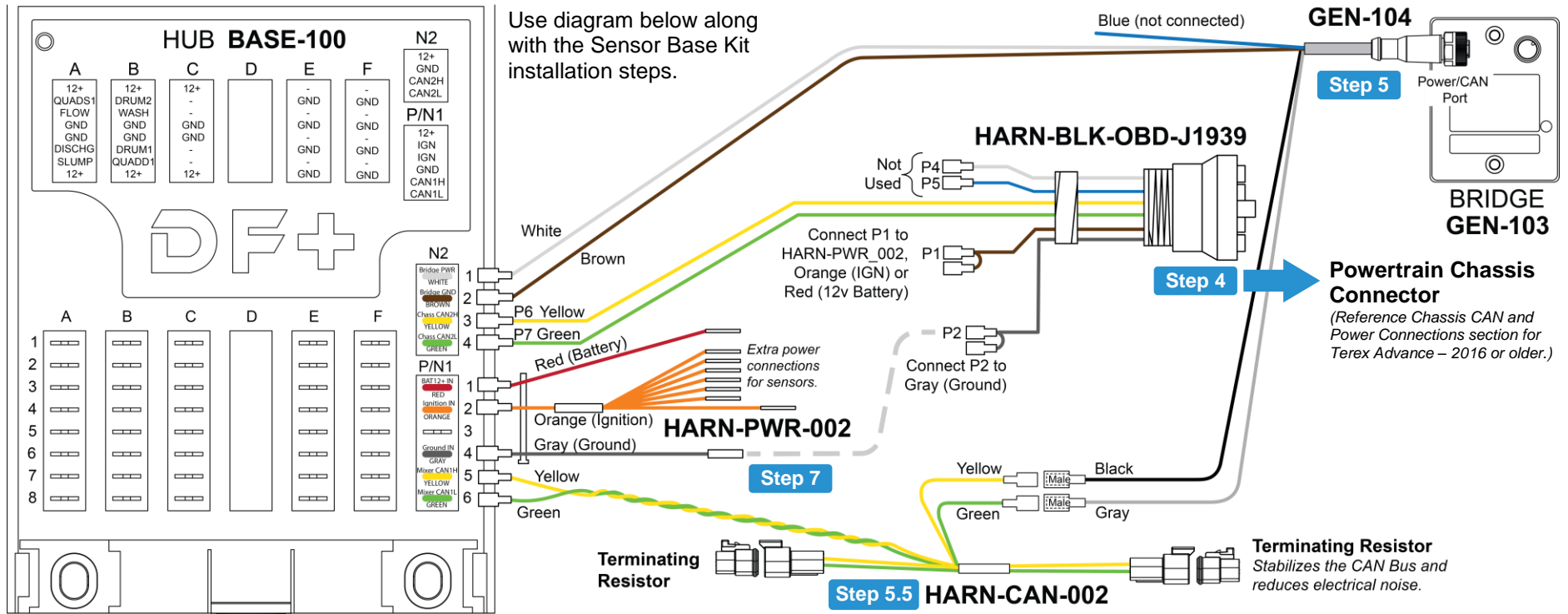

Step 4. Connect Hub to Chassis Powertrain Connector (use HARN-BLK-OBD-J1939)

1. Locate the diagnostic port in truck cab; reference Chassis CAN and Power Connections section for Terex Advance – 2016 or older.

If diagnostic port is currently in use (or used by service technicians), use a splitter (sold separately) to keep the port available when the OBD harness is plugged in.

2. Plug HARN-BLK-OBD-J1939 into diagnostic port.
3. Plug HARN-BLK-OBD-J1939 wires (P6 yellow and P7 green) into Hub, see diagram.

Important: When routing wires to Hub, follow an existing wire path, or remove a rubber hole plug—watch for sharp edges, use a grommet or bushing on holes to prevent wire damage.

Step 5. Connect Bridge to Hub (use GEN-104)

- 5.1. Plug GEN-104 into Power/CAN port on Bridge.
- 5.2. Blue wire not used.

Use diagram below along with the Sensor Base Kit installation steps.

- 5.3. Strip remaining wires—crimp on terminals.
 - white/brown—female terminals (GEN-101)
 - black/gray—male terminals (GEN-110)
- 5.4. Plug white and brown wires into Hub, see diagram.

HARN-CAN-002

- 5.5. Connect black and gray wires to HARN-CAN-002.
- 5.6. Plug HARN-CAN-002 into Hub, see diagram.
- 5.7. Truck **does not** have a mixer CAN Bus—a terminating resistor is preinstalled in each connector (do not remove), see diagram.

Step 6. Test for Chassis Power or Ignition Connection

- 6.1. **Use a Test Light** (or multimeter) to determine if you will connect to ignition or 12v constant power.

With OBD harness plugged into diagnostic port:

 - a. Put one Test Light lead into HARN-BLK-OBD-J1939 (P1) 12v battery power wire end.
 - b. Put the other Test Light lead into HARN-OBD-001 (P2) ground wire end.

- c. If light goes ON and OFF when key is turned on and off, connect to ignition.
- d. If light stays ON when key is turned off, connect to 12v battery power).

Step 7. Connect Hub to Chassis Ground and to either Power or Ignition (use HARN-PWR-002)

- 7.1. Long harness wires (red, orange, and gray) have a TE terminal end (for a splice block). Cut terminal end off, strip end, and crimp on male terminals (GEN-110).

Note: Extra orange wires are provided for sensors, if needed. Connect sensors before connecting battery power to Hub (see sensor section).

- 7.2. Connect the **female** terminal ends to Hub, see diagram: Orange (IGN) to N1-2; Gray (GND) to N1-4; Red (Battery PWR) to N1-1.
- 7.3. Connect the Gray (GND) **long wire end** to P2 Gray (GND wire) on OBD harness, see diagram.
- 7.4. Connect **EITHER** the Red (Battery PWR) or Orange (IGN) **long wire end** to P1 power wire on OBD harness as determined by Step 6 test, see diagram.

Wire Diagram 11 Sensor Base (Oshkosh S Series Flex 2.0)

Use diagram below along with the Sensor Base Kit installation steps.

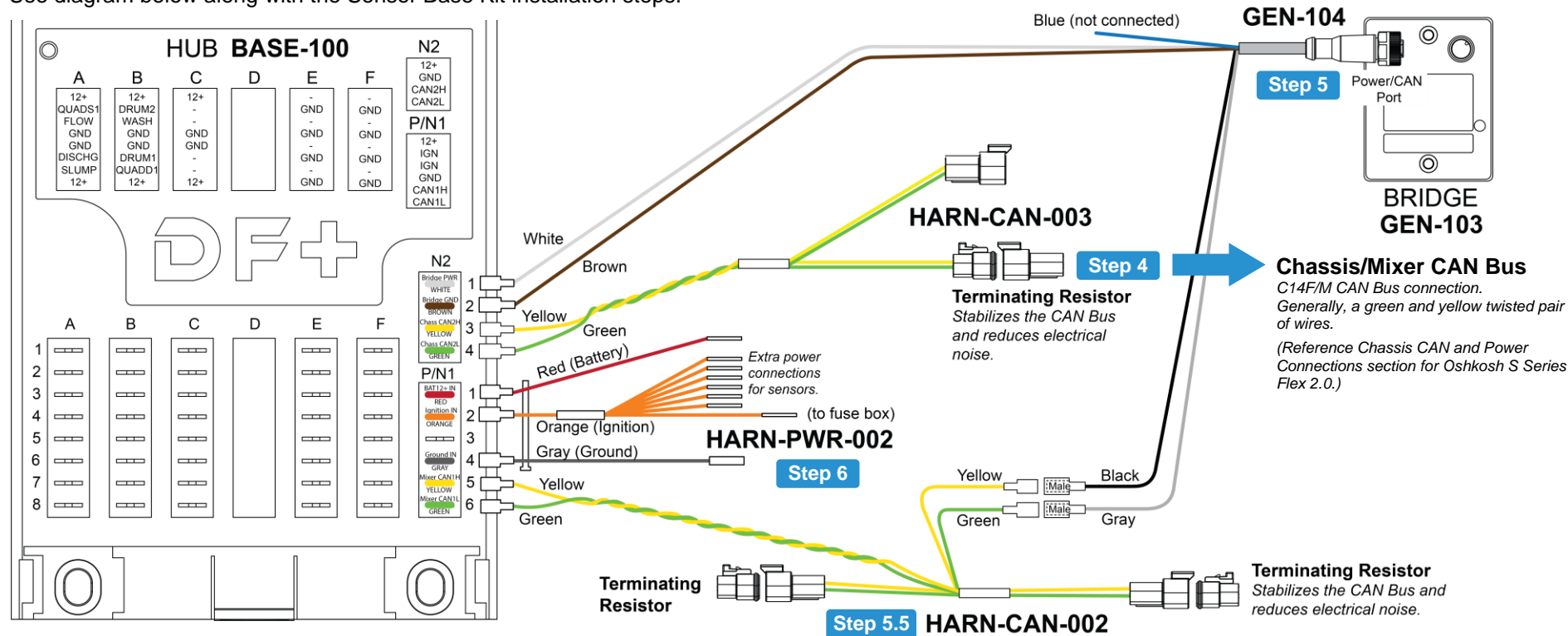

Step 4. Connect Hub to Chassis/Mixer CAN Bus (use HARN-CAN-003)

- 4.1. Chassis and Mixer are on the same CAN Bus—look for the C14F/M CAN Bus connection, by the driver's left leg (connector is labeled); reference Chassis CAN and Power Connections section for Oshkosh S Series Flex 2.0.
- 4.2. Plug HARN-CAN-003 into C14F/M CAN Bus connection, see diagram.
- 4.3. **Plug a terminating resistor** into remaining connector on the harness.
- 4.4. Plug HARN-CAN-003 into Hub, see diagram.

Important: When routing wires to Hub, follow an existing wire path, or remove a rubber hole plug—watch for sharp edges, use a grommet or bushing on holes to prevent wire damage.

Step 5. Connect Bridge to Hub (use GEN-104)

- 5.1. Plug GEN-104 into Power/CAN port on Bridge.
- 5.2. Blue wire not used.
- 5.3. Strip remaining wires—crimp on terminals.
 - white/brown—female terminals (GEN-101)
 - black/gray—male terminals (GEN-110)
- 5.4. Plug white and brown wires into Hub, see diagram.

HARN-CAN-002

- 5.5. Connect black and gray wires to HARN-CAN-002.
- 5.6. Plug HARN-CAN-002 into Hub, see diagram.
- 5.7. Truck **does not** have a mixer CAN Bus—a terminating resistor is preinstalled in each connector (do not remove), see diagram.

Step 6. Connect Hub to Chassis Power, Ignition, and Ground (use HARN-PWR-002)

- 6.1. Locate chassis connections for battery power, ignition, and ground—connections are labeled. **Always connect power or ground to Hub last.**
- 6.2. Long harness wires (red, orange, and gray) have a TE terminal end (for a splice block). If needed, cut terminal off, strip end, and crimp on appropriate terminal provided in kit (i.e., ring terminal).

Note: Extra orange wires are provided for sensors, if needed. Connect sensors before connecting battery power to Hub (see sensor section).
- 6.3. Connect **long wire ends** to truck connectors (i.e., splice blocks, terminal posts, bullet connections): Orange (to IGN); Gray (to GND); Red (to PWR)
- 6.4. Connect female terminal ends to Hub, see diagram: Orange (IGN) to N1-2; Gray (GND) to N1-4; Red (Battery PWR) to N1-1.

Wire Diagram 12 Sensor Base (Oshkosh S Series Non Flex): 3-way (no Mixer CAN)

Use diagram below along with the Sensor Base Kit installation steps.

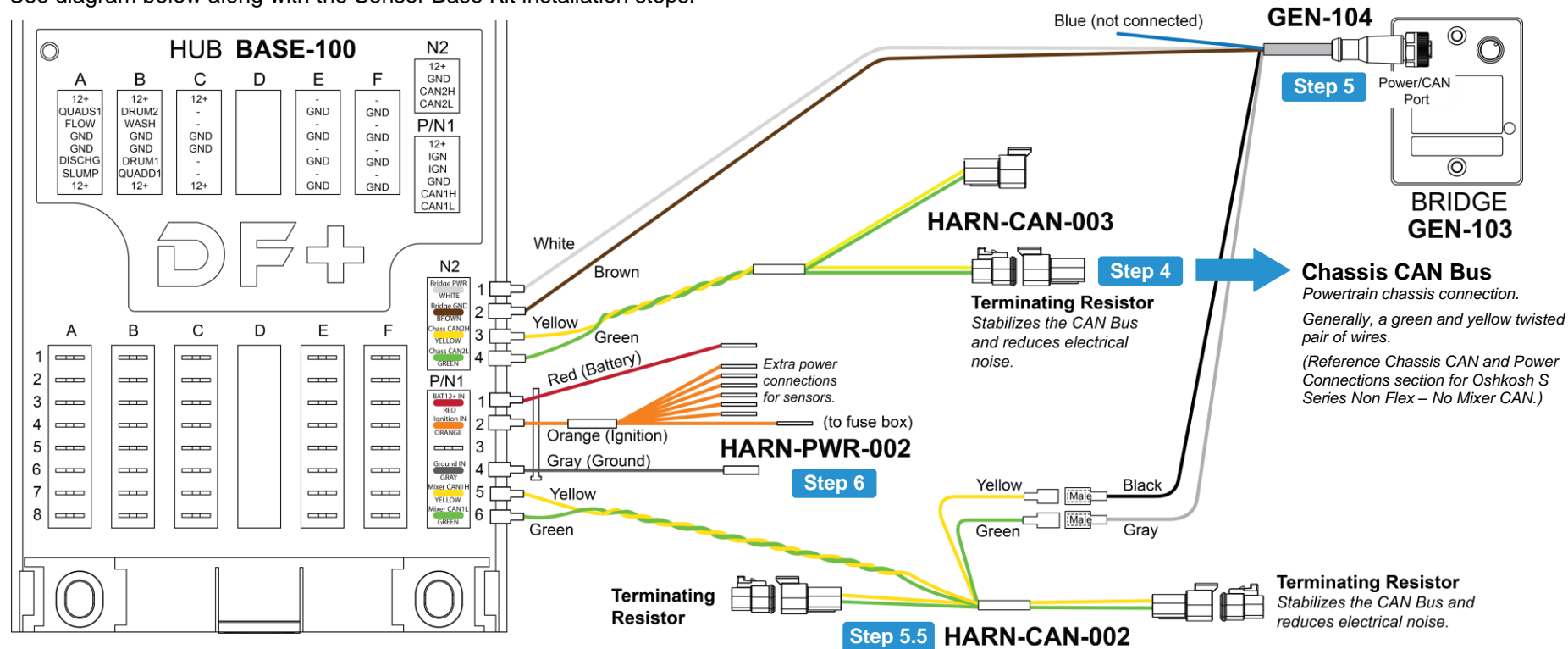

Step 4. Connect Hub to Chassis CAN Bus (use HARN-CAN-003)

- 4.1. Locate the powertrain chassis connector (connector is labeled)—reference Chassis CAN and Power Connections section for Oshkosh S Series Non Flex – No Mixer CAN.
- 4.2. Plug HARN-CAN-003 into powertrain chassis connection, see diagram.
- 4.3. **Plug a terminating resistor** into remaining connector on the harness.
- 4.4. Plug HARN-CAN-003 into Hub, see diagram.

Important: When routing wires to Hub, follow an existing wire path, or remove a rubber hole plug—watch for sharp edges, use a grommet or bushing on holes to prevent wire damage.

Step 5. Connect Bridge to Hub (use GEN-104)

- 5.1. Plug GEN-104 into Power/CAN port on Bridge.
- 5.2. Blue wire not used.
- 5.3. Strip remaining wires—crimp on terminals.
 - white/brown—female terminals (GEN-101)
 - black/gray—male terminals (GEN-110)
- 5.4. Plug white and brown wires into Hub, see diagram.

HARN-CAN-002

- 5.5. Connect black and gray wires to HARN-CAN-002.
- 5.6. Plug HARN-CAN-002 into Hub, see diagram.
- 5.7. Truck **does not** have a mixer CAN Bus—a terminating resistor is preinstalled in each connector (do not remove), see diagram.

Step 6. Connect Hub to Chassis Power, Ignition, and Ground (use HARN-PWR-002)

- 6.1. Locate chassis connections for battery power, ignition, and ground—connections are labeled. **Always connect power or ground to Hub last.**
- 6.2. Long harness wires (red, orange, and gray) have a TE terminal end (for a splice block). If needed, cut terminal off, strip end, and crimp on appropriate terminal provided in kit (i.e., ring terminal).

Note: Extra orange wires are provided for sensors, if needed. Connect sensors before connecting battery power to Hub (see sensor section).
- 6.3. Connect **long wire ends** to truck connectors (i.e., splice blocks, terminal posts, bullet connections): Orange (to IGN); Gray (to GND); Red (to PWR)
- 6.4. Connect female terminal ends to Hub, see diagram: Orange (IGN) to N1-2; Gray (GND) to N1-4; Red (Battery PWR) to N1-1.

Wire Diagram 13 Sensor Base (Oshkosh S Series Non Flex): 6-way (no Mixer CAN)

Use diagram below along with the Sensor Base Kit installation steps.

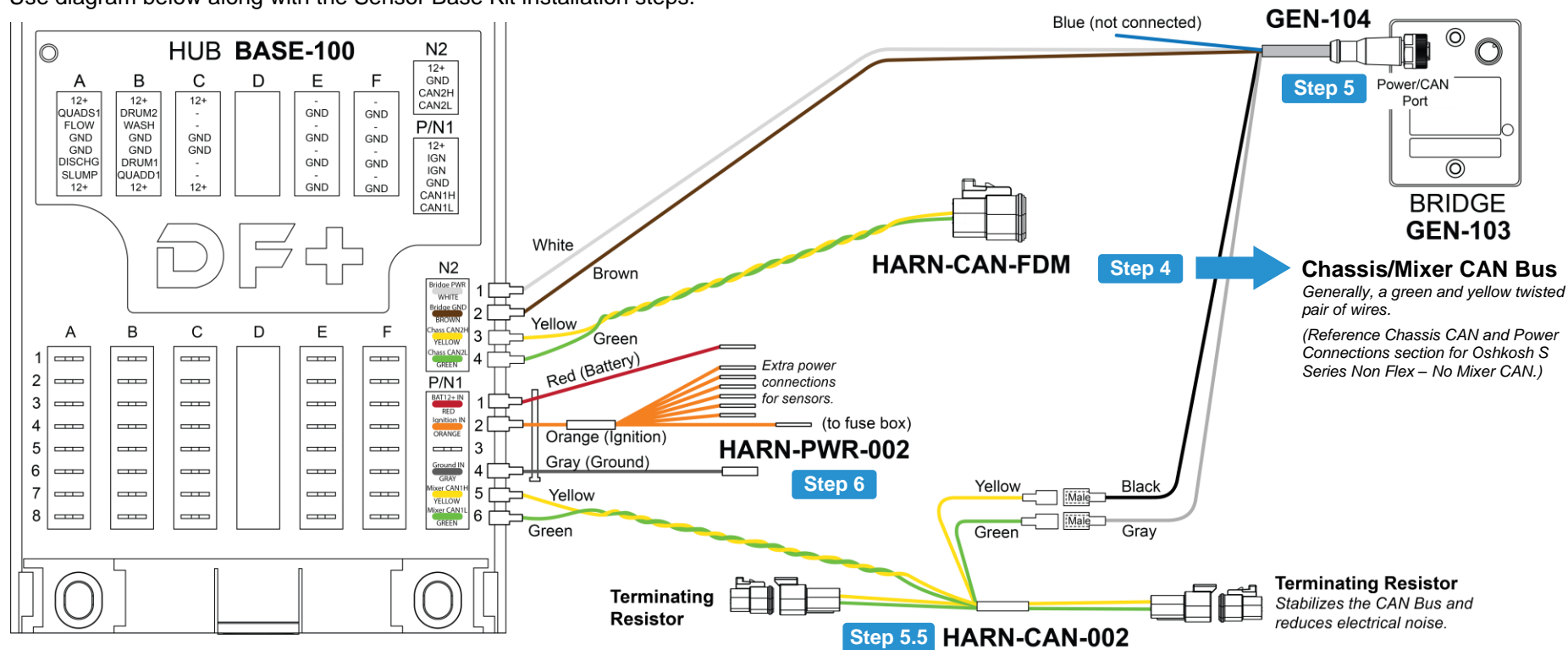

Step 4. Connect Hub to Chassis CAN Bus (use HARN-CAN-FDM)

- 4.1. Locate chassis CAN connector (connector is labeled)—reference Chassis CAN and Power Connections section for Oshkosh S Series Non Flex – No Mixer CAN.
- 4.2. Plug HARN-CAN-FDM into CAN Bus connection, see diagram.
- 4.3. Plug HARN-CAN-FDM into Hub, see diagram.

Important: When routing wires to Hub, follow an existing wire path, or remove a rubber hole plug—watch for sharp edges, use a grommet or bushing on holes to prevent wire damage.

Step 5. Connect Bridge to Hub (use GEN-104)

- 5.1. Plug GEN-104 into Power/CAN port on Bridge.
- 5.2. Blue wire not used.
- 5.3. Strip remaining wires—crimp on terminals.
 - white/brown—female terminals (GEN-101)
 - black/gray—male terminals (GEN-110)
- 5.4. Plug white and brown wires into Hub, see diagram.

HARN-CAN-002

- 5.5. Connect black and gray wires to HARN-CAN-002.
- 5.6. Plug HARN-CAN-002 into Hub, see diagram.
- 5.7. Truck **does not** have a mixer CAN Bus—a terminating resistor is preinstalled in each connector (do not remove), see diagram.

Step 6. Connect Hub to Chassis Power, Ignition, and Ground (use HARN-PWR-002)

- 6.1. Locate chassis connections for battery power, ignition, and ground—connections are labeled. **Always connect power or ground to Hub last.**
- 6.2. Long harness wires (red, orange, and gray) have a TE terminal end (for a splice block). If needed, cut terminal off, strip end, and crimp on appropriate terminal provided in kit (i.e., ring terminal).

Note: Extra orange wires are provided for sensors, if needed. Connect sensors before connecting battery power to Hub (see sensor section).

- 6.3. Connect **long wire ends** to truck connectors (i.e., splice blocks, terminal posts, bullet connections): Orange (to IGN); Gray (to GND); Red (to PWR)
- 6.4. Connect female terminal ends to Hub, see diagram: Orange (IGN) to N1-2; Gray (GND) to N1-4; Red (Battery PWR) to N1-1.

Wire Diagram 14 Sensor Base (Oshkosh S Series Non Flex): Glider (no Chassis/Mixer CAN)

Use diagram below along with the Sensor Base Kit installation steps.

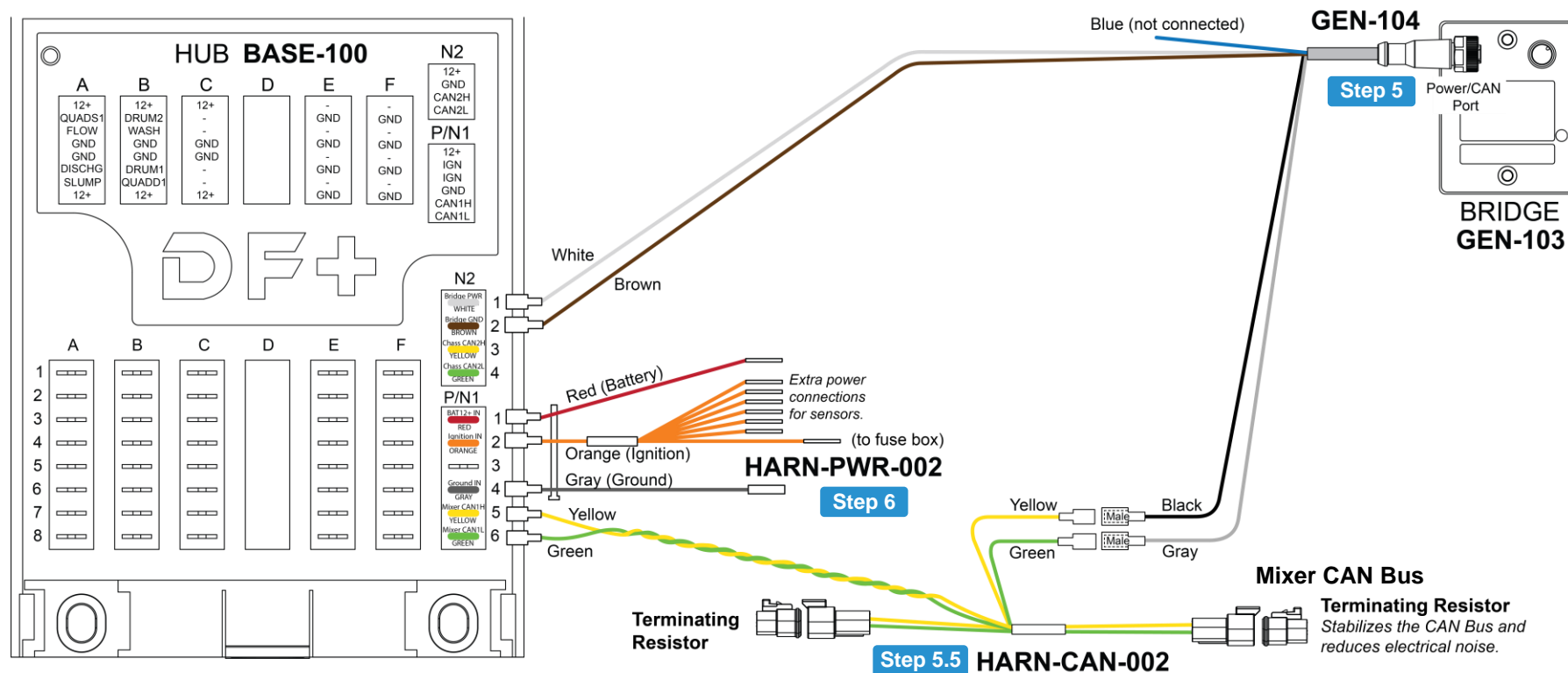

Step 4. Glider without Chassis CAN

No CAN harness required.

Step 5. Connect Bridge to Hub (use GEN-104)

- 5.1. Plug GEN-104 into Power/CAN port on Bridge.
- 5.2. Blue wire not used.
- 5.3. Strip remaining wires—crimp on terminals.
 - white/brown—female terminals (GEN-101)
 - black/gray—male terminals (GEN-110)
- 5.4. Plug white and brown wires into Hub, see diagram.

HARN-CAN-002

- 5.5. Connect black and gray wires to HARN-CAN-002.
- 5.6. Plug HARN-CAN-002 into Hub, see diagram.

- 5.7. Truck **does not** have a mixer CAN Bus—a terminating resistor is preinstalled in each connector (do not remove), see diagram.

Step 6. Connect Hub to Chassis Power, Ignition, and Ground (use HARN-PWR-002)

- 6.1. Locate chassis connections for battery power, ignition, and ground—connections are labeled. **Always connect power or ground to Hub last.**
- 6.2. Long harness wires (red, orange, and gray) have a TE terminal end (for a splice block). If needed, cut terminal off, strip end, and crimp on appropriate terminal provided in kit (i.e., ring terminal).

Note: Extra orange wires are provided for sensors, if needed. Connect sensors before connecting battery power to Hub (see sensor section).

- 6.3. Connect **long wire ends** to truck connectors (i.e., splice blocks, terminal posts, bullet connections): Orange (to IGN); Gray (to GND); Red (to PWR)
- 6.4. Connect female terminal ends to Hub, see diagram: Orange (IGN) to N1-2; Gray (GND) to N1-4; Red (Battery PWR) to N1-1