

Water Add Kit – IFM Ultra (Freeze Resistant)

Items Included in the Kit

Unpack the kit and review its contents.

Label the Sensor Cable(s): Label **both ends** of the cable using colored tape or zip ties to identify its function when routed to the Hub.

Recommendations: Yellow – Slump Hydraulic Sensor
 Red – Drum Sensor (Drum 1)
 Green – Drum Sensor (Drum 2)
 Blue – Water Add Flow Meter
 White – Washout Switch

Flow Meter – IFM Ultra

Kit Quantity: 1

DF Part Number: [WATER-203](#)

(2) G1 to 1" Hose Barbs preinstalled (WATER-206)



M12 Cord Set, 20M Cable

Kit Quantity: 1

DF Part Number: [GEN-102](#)



Male Terminals

DF Part Number: [GEN-110](#)



Female Terminals

DF Part Number: [GEN-101](#)



1" SS Hose Clamps

Kit Quantity: 3

DF Part Number: [WATER-102](#)



Tools for the Job (not included)

- #2 Phillips screwdriver (or screw gun with #2 Phillips end)
- Flat screwdriver (or screw gun with flat end)
- Hose cutter
- Cable stripper (nice to have)
- Wire crimpers
- Wire strippers
- Side cutters

Additional Items Needed (not included)

- Grommets, bushings, hole plugs (to pass wiring through dash/firewall)
- Wire ties
- Colored tape (to mark cables)

Installation – Water Add Kit – IFM Ultra

The IFM Ultra Flow Meter is a freeze resistant sensor installed in the water add line going into the drum. This allows the driver and dispatch to monitor water added to the batch of concrete.

During Installation You Will:

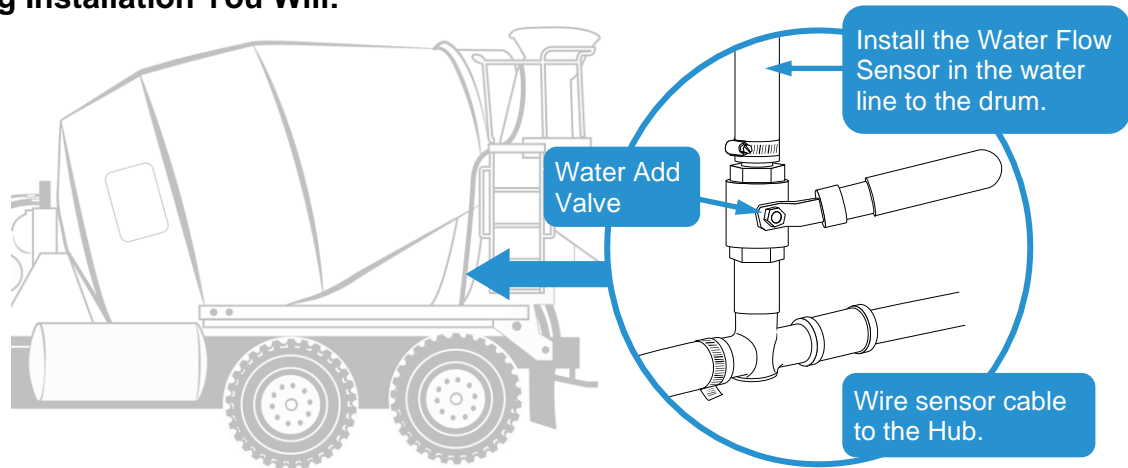

Step 1. Before starting—color code each end of the sensor cable to identify its function when routed to the hub (blue recommended for Flow Meter).

Step 2. Engine must be off, but leave battery connected.

Step 3. Start installation above the water add valve in the 1" water hose going to the drum.

Important: Vibration can cause false readings—install sensor where it will NOT vibrate against any object or surface.

Step 4. Drain the water add hose line.

Step 5. Use tape to mark the cutout section of the hose.



DO NOT cut the hose until you carefully measure the cutout section needed and mark any hidden fitting ends.

5.1. Mark the hose where the water valve fitting ends, see image.

5.2. Hold sensor in place against hose:

A. Make sure sensor barbs will clear any fittings.

B. Position sensor where it **will NOT vibrate** against any object or surface.

IMPORTANT: Allow enough space for sensor barb to clear valve fitting end.

5.3. Mark the sensor ends on the hose and mark a cutout section approx. 4", see image reference.

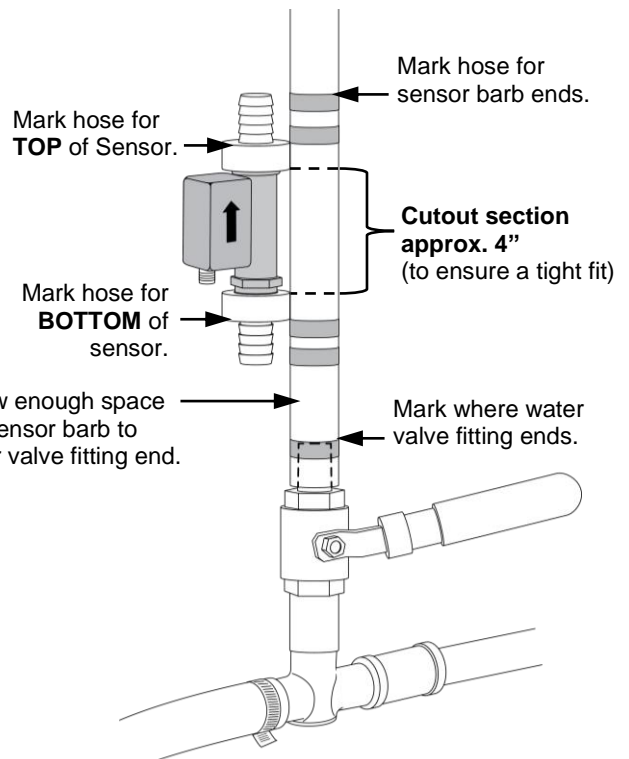

Step 6. Using a hose cutter—cut out the section of hose **approx. 4" long**.

Step 7. Install the Flow Meter (WATER-203) in the cutout section (the sensor should fit tight).

7.1. Arrow on sensor **MUST** go in direction of water flow—UP towards drum.

7.2. Face the cable connection towards the truck cab.

7.3. Use a hose clamp (WATER-102) to fasten each end of the sensor.

Fasten hose securely to avoid leaks.

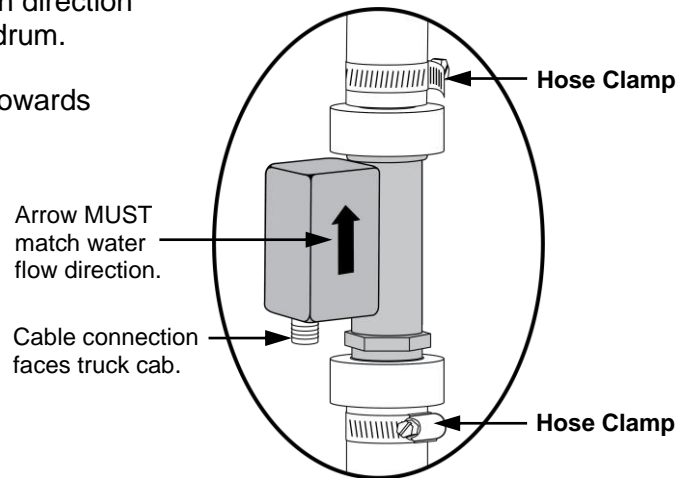

Step 8. Put a dab of **dielectric grease** on sensor pins to help prevent corrosion.

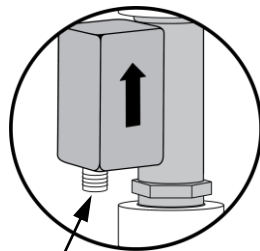

Cable Connection Sensor Pins

Step 9. Connect cable (GEN-102) to sensor end:

Do not force a connection—end should slide on easily, check key alignment.

Thread lock ring onto sensor until hand tight (ring clicks slightly when locked).

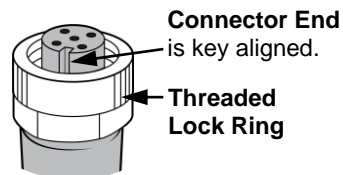

General reference image only (pins may vary).

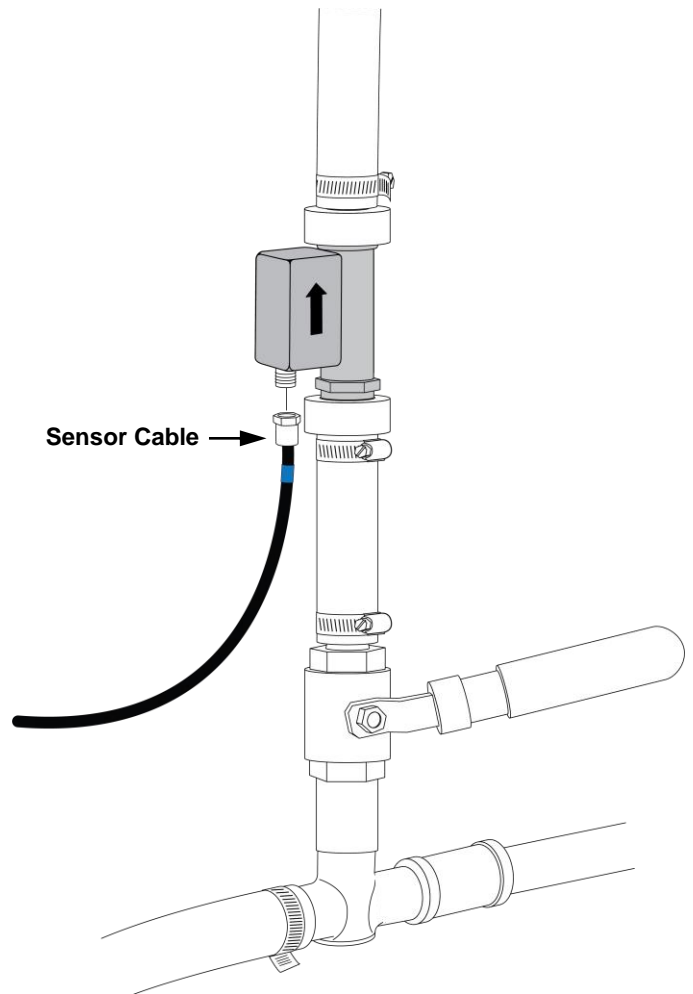

Step 10. Run cable so it **does not interfere** with valve handle turning or get bumped during normal operation.

WATER ADD IFM ULTRA SENSOR WIRING

To connect sensor wiring, you need to access the Hub, generally located in dash (Rear Discharge Mixers) or on back cab wall (Front Discharge Mixers).



**HUB
BASE-100**

Route Sensor Cable and Connect it to the Hub



If you have additional sensors to install, route all the cables together, then zip tie them to the frame as a group whenever possible.

Step 1. Route sensor cable(s) to the Hub—fasten cables approx. every foot.

Important: Route cables safely—avoid moving parts, pinch points, and sharp edges. Use a grommet or bushing on pass-thru holes as needed.

Rear Discharge Mixers: Run cable(s) through the frame rails, under the cab, through a hole in the firewall, and into the dash to connect to the Hub.

Front Discharge Mixers: Run cable(s) through the frame rails, up the back cab wall, and pass it thru a hole into the cab to connect to the Hub.

Step 2. BEFORE cutting any cable:

- 2.1. Measure enough cable length for Hub to be removed from the dash and set aside to work on it effectively.
- 2.2. **Move the color coding (tape)** so the cable can still be identified after being cut.
- 2.3. Cut off any extra cable length.

Step 3. Connect Flow Meter Sensor Cable to Hub (use GEN-102 Cable color coded for Water Add Flow Meter).

- 3.1. Black wire not used.
- 3.2. Strip remaining wires—crimp on terminals:
 - white—female terminal (GEN-101)
 - brown—male terminal (GEN-110)
 - blue—female terminal (GEN-101)
- 3.3. Plug white wire and blue wire into Hub, see image below.
- 3.4. Plug brown wire into power harness on Hub (HARN-PWR-002—strip one of the orange, extra power connection wires and crimp on a female terminal for use).

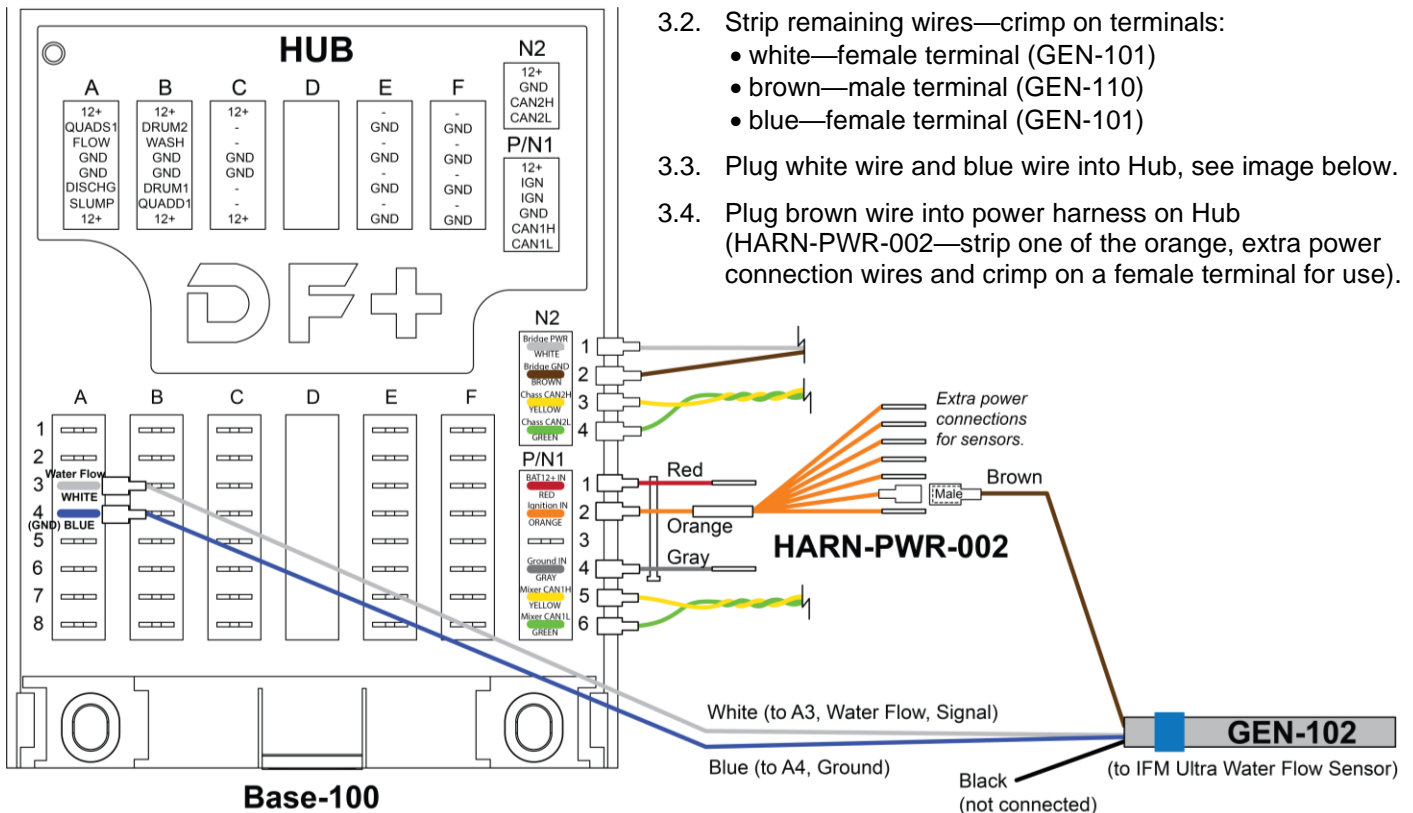

Step 4. Double check that all wiring connections are securely fastened.



If applicable, complete any additional sensor wiring to the Hub before testing each sensor (refer to the wiring instructions in each sensor's section).

Installer Verification

Step 1. Prepare the system for verification.

- 1.1. Make sure there is enough water in the tank for testing (min. approx. 5 gallons).
- 1.2. Turn the truck ON and if applicable, pressurize the tank.
- 1.3. Make sure the pump is enabled and ready for use.
- 1.4. Check hose connections for leaks—tighten hose clamps if needed.

Step 2. If possible, have the tablet near you to watch the reading on-screen as water is added.

Step 3. Verify the tablet shows correct water add reading:

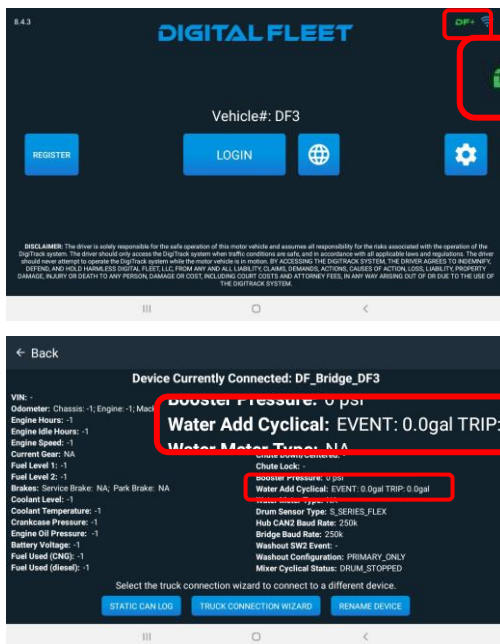

3.1 Press DF+ icon to navigate to the DF+ diagnostic screen.

3.2 On diagnostic screen—scroll down to the Water Add Cyclical reading.

- **Event** reading shows a **running total** as water is added to the drum.
- **Trip** reading is updated after the valve is closed to show total water amount added.

3.3 To test the system, add a minimum 5 gallons of water while observing the readings.

Note: By default, the system filters out any readings less than a gallon to avoid vibration noise. Reference troubleshooting section for noise filtering issues.

If **Event** reading displays an accurate running total, and **Trip** reading updates to match the water amount added, the Water Add Cyclical is verified. *(If incorrect, reference the Water Add IFM Ultra Troubleshooting section).*

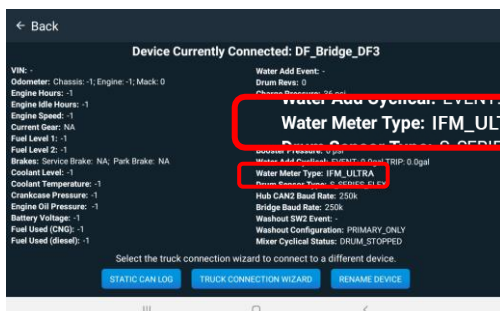





3.4 Scroll down to observe Water Meter Type—it should read IFM ULTRA. *(If incorrect, contact DF+ Support.)*

If the reading is correct, sensor installation is verified.

WATER ADD IFM ULTRA TROUBLESHOOTING

Issue	Possible Cause	Potential Solution
<p>Water was added, but no reading shows.</p>	<p>No water passing thru sensor</p>	<p>Water valve was turned on, but no water passes thru the sensor—make sure the tank has water in it.</p> <p>Waterlines must be drained after use when the temperature is below 40°F. Water freezing in the lines can block water flow.</p>
	<p>Noise filtering (reading too small to display)</p> <p>• Sensor is reading all the time</p>	<p>By default, the system is set up to filter out readings less than a gallon to help prevent vibration noise (false readings shown on the tablet).</p> <p>If the threshold is set too high, the system may not pick up all water add events—the default may need to be adjusted, contact DF+ Support.</p> <p>Recheck: Add a minimum of 5 gallons of water to the drum (to exceed any minimum threshold) to test the system again.</p> <p>See False readings section in the Troubleshooting below.</p>
	<p>Parameter setting on tablet</p>	<p>Check the Water Sensor Type shown on the diagnostic screen—it should read IFM ULTRA (reference sensor’s Installer Verification instructions section, Step 3.4).</p> <p>If incorrect, contact DF+ Support.</p>
	<p>Open circuit/short circuit (sensor to Hub)</p>	<p>Make sure sensor is installed properly in the 1” water add hose going to the drum—arrow indicator on sensor MUST point in direction of water flow (reference Water Add IFM Ultra Installation section, Step 7).</p> <p>Check cable connection at sensor end—key on cable connector aligns it to the sensor pins; lock ring threads onto sensor until hand tight (see Water Add IFM Ultra Installation section, Step 9).</p> <p>Check wire connections on Hub:</p> <p>Make sure sensor cable runs into the truck cab and all connections match the appropriate wire diagram (reference Water Add IFM Ultra Sensor Wiring section).</p> <p>Check ignition connections:</p> <ul style="list-style-type: none"> • Make sure brown wire is connected to orange wire of HARN-PWR-002 (ignition). • Make sure orange wire of HARN-PWR-002 is plugged into N1-2 (ignition) on Hub. <p>Check ground connections:</p> <ul style="list-style-type: none"> • Make sure blue wire is connected to A4 (ground) on Hub. • Make sure gray wire of HARN-PWR-002 is plugged into N1-4 (ground) on Hub. <p>Check Water Flow signal connection at Hub:</p> <ul style="list-style-type: none"> • Make sure white wire is connected to A3 (Water Flow Signal on Hub).

Issue	Possible Cause	Potential Solution
	Open circuit (Hub to truck)	<p>Make sure Hub is connected to chassis power, ground, and ignition (as applicable, reference Sensor Base section for the wire diagram that applies to your truck).</p> <p>Verify truck has proper fuses installed; make sure fuses are not blown.</p>
	Damaged wiring	<p>Inspect cable length for damage. Check sensor pins for damage—remove cable end from sensor to inspect pins.</p> <p>Whenever cable is disconnected, clean end and put a dab of dielectric grease on sensor pins before reconnecting.</p> <p>Visually check the cable length for damage—make sure it has not been pinched, nicked, or damaged in any way.</p> <p>Check for any type of damage, for example:</p> <p>Frayed harness or wire </p> <p>Pinched wire or harness </p> <p>Cut or exposed wire </p> <p>Burned or hot wire (discolored or distorted covering) </p> <p>For any damage to the wiring or plug ends, replace the cable (reference the sensor's, Installation section).</p>
	Damaged sensor	<p>Visually inspect the sensor. If it is cracked/leaks water, or looks physically damaged, replace the sensor (reference Water Add IFM Ultra Installation section, Step 7).</p> <p>Waterlines must be drained after use when the temperature is below 40°F. Water freezing in the lines can block water flow.</p>
False readings	Vibration issues	<p>Make sure the sensor is not able to vibrate against any object or surface during transit or use.</p> <p>By default, the system is set up to filter out readings less than a gallon to help prevent vibration noise (false readings).</p> <p>If the threshold is set too low, the system may show false readings (readings all the time or outside of water add events)—the default may need to be adjusted, contact DF+ Support.</p> <p>If the system is not showing actual water add events, see the Noise filtering section above.</p>
Other issues check ok, but sensor still not working.		<p>Replace the sensor (reference Water Add Kit IFM Ultra Installation, section Step 7).</p>

For installation or troubleshooting questions, please call DF+ Support at 630.518.4606.